

Model No. VC3211M VACUUM CLEANER

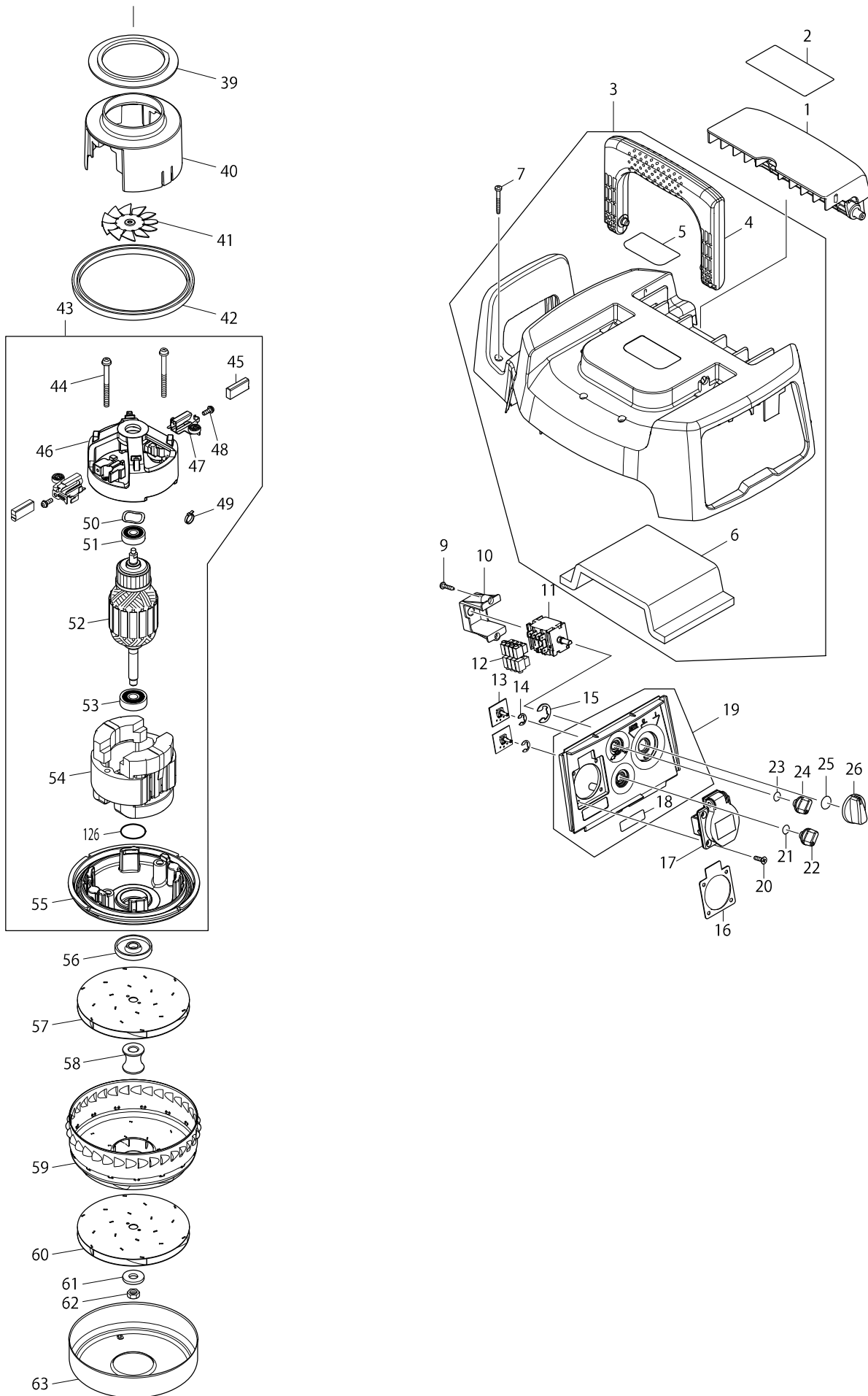

Model No. VC3211M VACUUM CLEANER

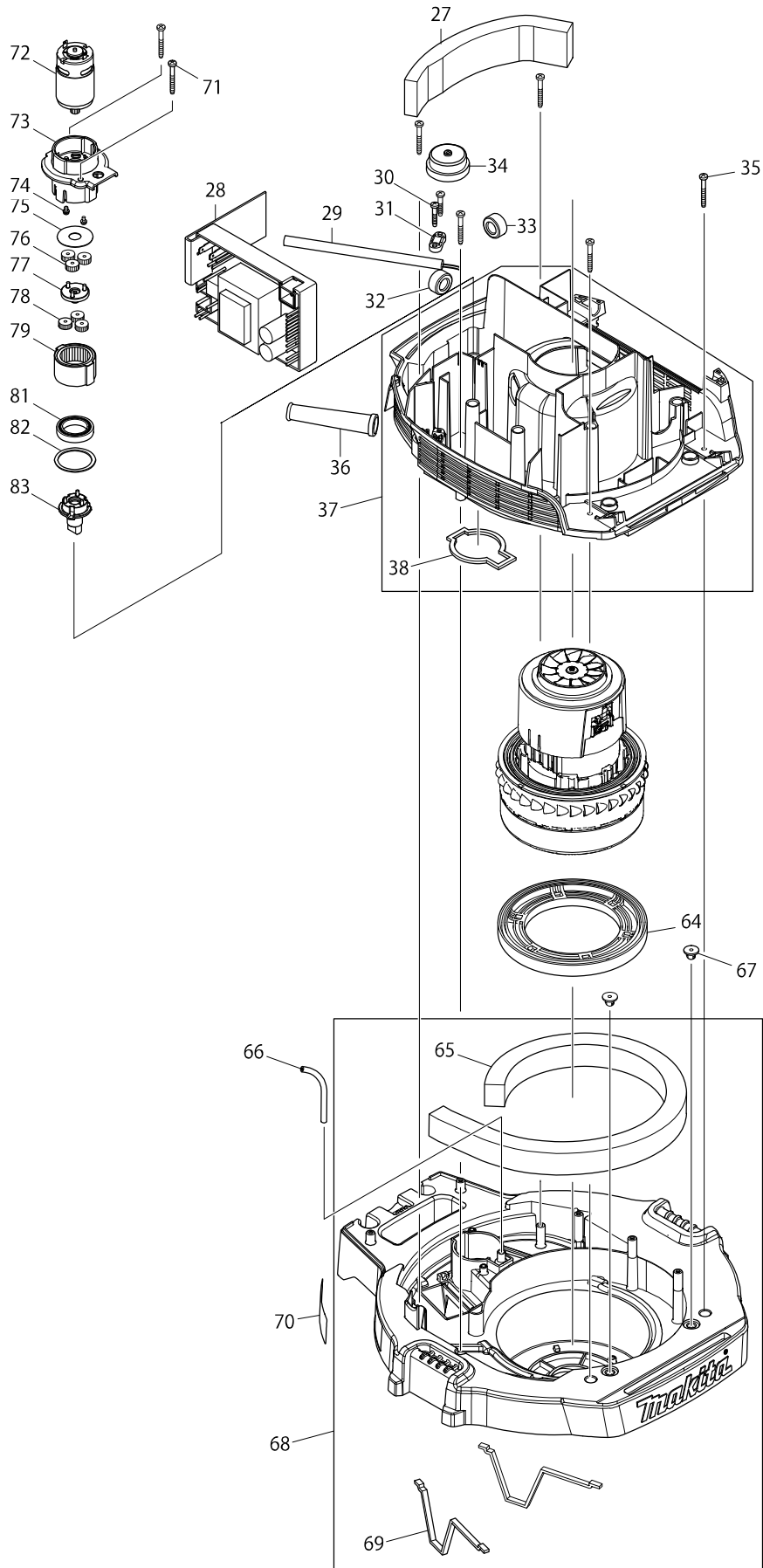

Model No. VC3211M VACUUM CLEANER

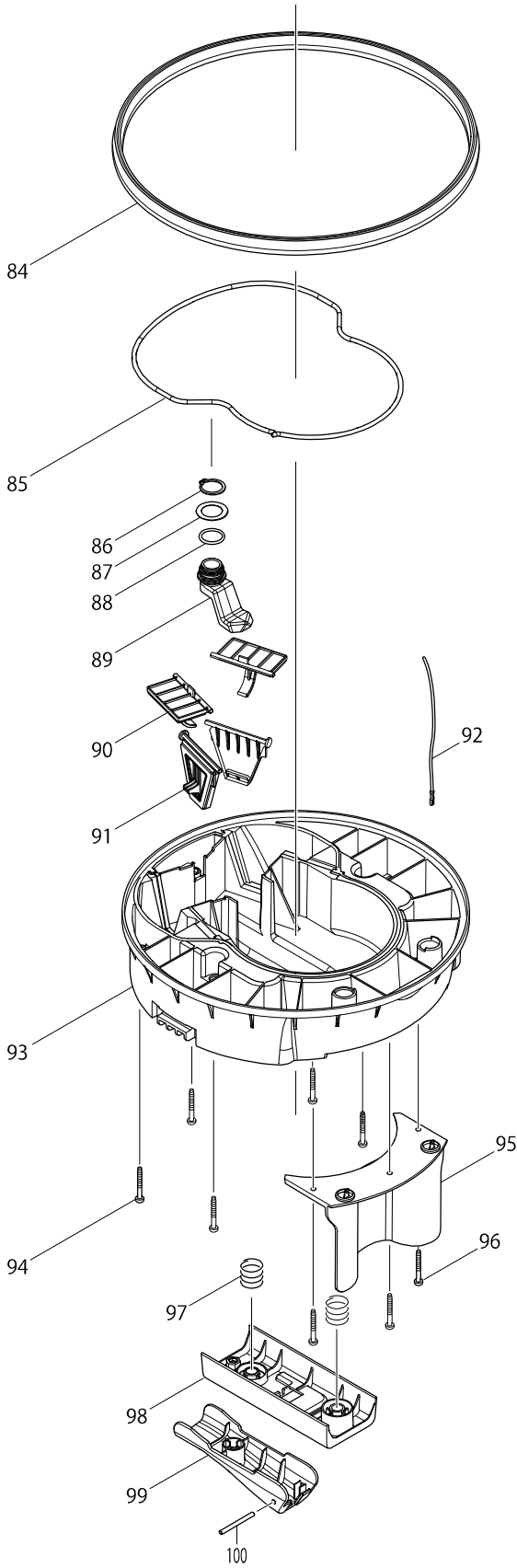

Model No. VC3211M VACUUM CLEANER

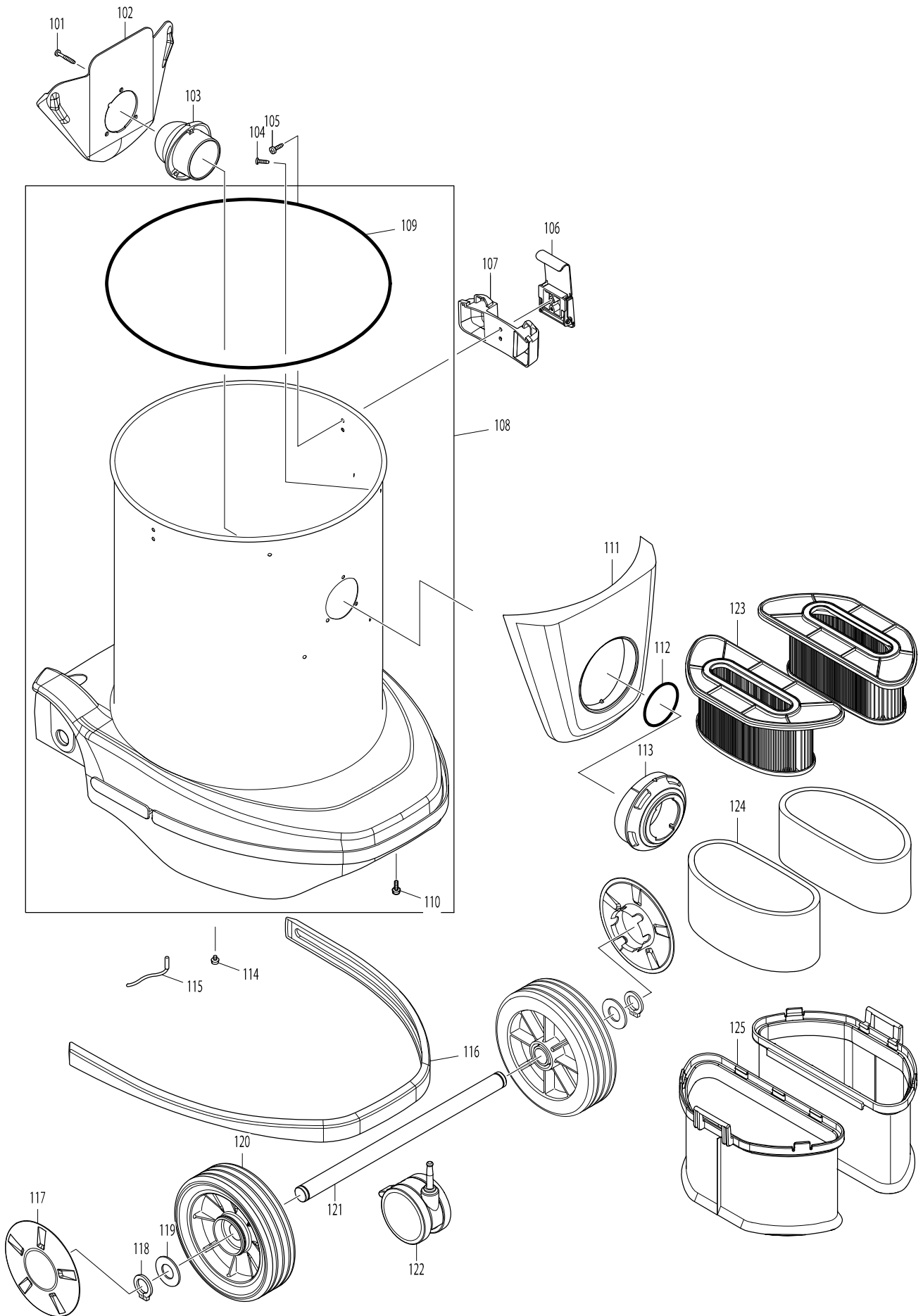

Model No. VC3211M VACUUM CLEANER

Item	Parts No.	Description	I/C	QTY	N/O	Opt. 1	Opt. 2	NOTE
001	452451-7	BASE HOOK		1		100		
002	800W80-2	CAUTION LABEL		1		100		
003	141915-3	COWLING COMPLETE		1		100		
D10		INC. 4-6						
004	451340-3	GRIP		1		100		
005	891977-8	CAUTION LABEL		1		100		
006	423456-4	TOP DAMPER		1		100		
007	266053-1	TAPPING SCREW 4X35		9		100		
009	265995-6	TAPPING SCREW 4X18		2		100		
010	451343-7	SWITCH HOLDER		1		100		
011	650659-9	SWITCH		1		100		
012	686023-8	RECEPTACLE SLEEVE		8		100		
013	620185-2	SUB CONTROLLER		1		100		
014	961013-5	STOP RING E-7		2		100		
015	961062-2	STOP RING E-12		1		100		
016A	685741-5	RUBBER SHEET		1		100		
016B	685740-7	RUBBER SHEET		1		100		
016C	685741-5	RUBBER SHEET		1		100		
016D	685740-7	RUBBER SHEET		1		100		
017A	655125-1	OUTLET		1		100		
017B	655124-3	OUTLET		1		100		
017C	655125-1	OUTLET		1		100		
017D	655124-3	OUTLET		1		100		
018A	800W84-4	CAUTION LABEL		1		100		
018B	800W85-2	CAUTION LABEL		1		100		
018C	800W84-4	CAUTION LABEL		1		100		
018D	800W85-2	CAUTION LABEL		1		100		
D10		INC. 18						
019A	141914-5	SWITCH BASE LB-M COMPLETE		1		100		
019B	141913-7	SWITCH BASE HB-M COMPLETE		1		100		
019C	141914-5	SWITCH BASE LB-M COMPLETE		1		100		
019D	141913-7	SWITCH BASE HB-M COMPLETE		1		100		
020A	266630-9	+COUNTERSUNK TAPPING SCREW4X		4		100		
020B	266640-6	+COUNTERSUNK TAPPING SCREW4X		4		100		
020C	266630-9	+COUNTERSUNK TAPPING SCREW4X		4		100		
020D	266640-6	+COUNTERSUNK TAPPING SCREW4X		4		100		
021	213054-0	O RING 9		1		100		
022	451344-5	SWITCH DIAL		1		100		
023	213054-0	O RING 9		1		100		
024	451344-5	SWITCH DIAL		1		100		
025	213176-6	O RING 14		1		100		
026	451342-9	SWITCH LEVER		1		100		
027	423450-6	REAR BLOCK FILTER		1		100		
028A	620183-6	CONTROLLER		1	*	100		
028B	620184-4	CONTROLLER		1	*	100		
028C	620183-6	CONTROLLER		1	*	100		
028D	620184-4	CONTROLLER		1	*	100		
028-1A	620466-4	CONTROLLER	<	1				

Model No. VC3211M VACUUM CLEANER

Item	Parts No.	Description	I/C	QTY	N/O	Opt. 1	Opt. 2	NOTE
028-1B	620467-2	CONTROLLER	<	1				
028-1C	620466-4	CONTROLLER	<	1				
028-1D	620467-2	CONTROLLER	<	1				
029A	695360-9	POWER SUPPLY CORD 1.5-3-5.0		1		100		
029B	692450-9	POWER SUPPLY CORD 1.5-3-5.0		1		100		
029C	695360-9	POWER SUPPLY CORD 1.5-3-5.0		1		100		
029D	692450-9	POWER SUPPLY CORD 1.5-3-5.0		1		100		
030	265999-8	TAPPING SCREW 4X25		2		100		
031	687149-9	STRAIN RELIEF		1		100		
032	688131-1	LINE FILTER		1		100		
033	688131-1	LINE FILTER		1		100		
034	620186-0	BUZZER CIRCUIT		1		100		
035	266053-1	TAPPING SCREW 4X35		5		100		
036	682575-7	CORD GUARD 12-90		1		100		
037	141917-9	SEPARATOR COMPLETE		1		100		
D10		INC. 38						
038	423462-9	DC MOTOR SEAL		1		100		
039	423279-0	SEAL RING 70		1		100		
040	451338-0	MOTOR COVER		1		100		
041	241512-6	FAN 62		1		100		
042	424228-0	RUBBER RING 120		1		100		
D10		INC. 44-50,52,54,55,126						
043A	125873-1	MOTOR ASSEMBLY		1		100		
043B	125876-5	MOTOR ASSEMBLY		1		100		
043C	125873-1	MOTOR ASSEMBLY		1		100		
043D	125876-5	MOTOR ASSEMBLY		1		100		
044	911283-6	PAN HEAD SCREW M5X60		2		100		
045	195483-8	CARBON BRUSH CB-173		1		100		
046	452106-4	ENDBELL		1		100		
047A	643663-5	BRUSH HOLDER 6.5X13.5		2		100		
047B	643610-6	BRUSH HOLDER 6.5X13.5		2		100		
047C	643663-5	BRUSH HOLDER 6.5X13.5		2		100		
047D	643610-6	BRUSH HOLDER 6.5X13.5		2		100		
048	911118-1	PAN HEAD SCREW M4X12		2		100		
049	687010-0	BAND		1		100		
050	267715-4	WAVE WASHER 20		1		100		
051	211092-6	BALL BEARING 629DDW		1		100		
D10		INC. 51,53						
052A	517845-4	ARMATURE ASSEMBLY 100V		1		151		
052B	517849-6	ARMATURE ASS'Y 240V		1		151		
052C	517845-4	ARMATURE ASSEMBLY 100V		1		151		
052D	517849-6	ARMATURE ASS'Y 240V		1		151		
053	211087-9	BALL BEARING 6200DDW		1		100		
C10	654304-8	RECEPTACLE		2		100		
054A	526201-7	FIELD ASS'Y 115V		1		152		
054B	526204-1	FIELD ASS'Y 240V		1		152		
054C	526201-7	FIELD ASS'Y 115V		1		152		
054D	526204-1	FIELD ASS'Y 240V		1		152		

Model No. VC3211M VACUUM CLEANER

Item	Parts No.	Description	I/C	QTY	N/O	Opt. 1	Opt. 2	NOTE
055	454480-6	BASE		1	100			
056	316795-8	FLANGE		1	100			
057	241910-4	FAN 125		1	100			
058	325747-8	SPACER		1	100			
059	346114-4	RETURN VANE		1	100			
060	241910-4	FAN 125		1	100			
061	316799-0	FLAT WASHER 10		1	100			
062	931403-6	HEX. NUT M8		1	100			
063	346115-2	FAN COVER		1	100			
064	424229-8	SUPPORT RING		1	100			
065	423451-4	BAND DAMPER		1	100			
066	684900-8	VYNIL TUBE		1	100			
067	421468-1	CORD SEAL		2	100			
068	141916-1	TANK COVER COMPLETE		1	100			
D10		INC. 65,69						
069	423455-6	VALVE SEAL		2	100			
070	814D82-8	VC3211M NAME PLATE		1	100			
071	266053-1	TAPPING SCREW 4X35		2	100			
072	629981-5	DC MOTOR		1	100			
073	454207-4	GEAR CASE		1	100			
074	911003-8	PAN HEAD SCREW M3X6		2	100			
075	267067-3	FLAT WASHER 12		1	100			
076	226283-6	SPUR GEAR 15		3	100			
077	153228-0	SPUR GEAR 9 COMPLETE		1	100			
078	226284-4	SPUR GEAR 15		3	100			
079	226285-2	INTERNAL GEAR 42		1	100			
081	211375-4	BALL BEARING 6805LLB		1	100			
082	267464-3	FLAT WASHER 34		1	100			
083	135554-9	SPINDLE ASSEMBLY		1	100			
084	424543-2	RUBBER RING		1	100			
085	424544-0	SEAL RING		1	100			
086	961060-6	RETAINING RING S-20		1	100			
087	267041-1	FLAT WASHER 20		1	100			
088	213304-3	O RING 20		1	100			
089	454208-2	CAM		1	100			
090	141919-5	OUTER VALVE COMPLETE		2	100			
091	141918-7	INNER VALVE COMPLETE		2	100			
092	632A68-0	LEAD UNIT		2	100			
093	454204-0	INNER COVER		1	100			
094	266053-1	TAPPING SCREW 4X35		5	100			
095	454209-0	PROTECTOR		1	100			
096	266053-1	TAPPING SCREW 4X35		3	100			
097	234273-5	COMPRESSION SPRING 20		2	100			
098	454215-5	LOCK PLATE		1	100			
099	454214-7	LOCK LEVER		1	100			
100	268292-9	PIN 4		1	100			
101	266257-5	TAPPING SCREW 4X28		3	100			
102	417587-9	HOLDER PLATE		1	100			

Model No. VC3211M VACUUM CLEANER

Item	Parts No.	Description	I/C	QTY	N/O	Opt. 1	Opt. 2	NOTE
103	451455-6	HOLDER		1		100		
104	266192-7	TAPPING SCREW 4X14		4		100		
105	266192-7	TAPPING SCREW 4X14		4		100		
106	168537-4	HOOK		2		100		
107	451545-5	HOOK SUPPORTER		2		100		
108	188824-5	TANK SET		1		100		
D10		INC. 109,110						
109	424346-4	RUBBER RING T		1		100		
110	911118-1	PAN HEAD SCREW M4X12		1		100		
111	451546-3	INLET COVER		1		100		
112	213655-4	O RING 56		1		100		
113	451454-8	INLET		1		100		
114	911103-4	PAN HEAD SCREW M4X6		1		100		
115	649150-2	EARTH LINE 120		1		100		
116	424270-1	BUMPER		1		100		
117	451643-5	WHEEL CAP		2		100		
118	961060-6	RETAINING RING S-20		2		100		
119	267299-2	FLAT WASHER 20		2		100		
120	451642-7	CASTER 170		2		100		
121	331888-0	JOINT PIPE 20-350		1		100		
122	168547-1	CASTER 75		1		100		
123	141875-9	POWDER FILTER M COMPLETE		2		100		
124	423452-2	DAMPER		2		100		
125	196253-8	PRE-FILTER SET		2				
126	213406-5	O RING 30		1		100		
A01	195433-3	HOSE COMPLETE 28-3.5 SET		1	*			
D10		INC. A02,A03			*			
A01-1	195433-3	HOSE COMPLETE 28-3.5 SET	O	1				
C20	417191-4	CUFF LOCK		1				
C30	417586-1	STOPPER		1				
C40	417662-1	SLEEVE		1				
C50	417766-9	FRONT CUFF 38		1				
D10		INC. A02,A03						
A02	417765-1	FRONT CUFF 22		1				
A03	424379-9	FRONT CUFF 24		1				
A04	141873-3	BELT HOOK COMPLETE		1				
A05	166116-2	HOSE BAND		2				
A06	195440-6	POLY BAG SET		1				
A07	424545-8	CAP		1				
A08C	122512-4	NOZZLE ASS'Y		1				
C01	151449-8	ROLLER 40 COMPLETE		2				
C06	415962-3	ROLLER 14		2				
C11	256241-8	PIN 3		2				
C16	265871-4	TAPPING SCREW BT 4X16		6		100		
C21	154427-7	ELBOW JOINT COMPLETE		1				
C26	415965-7	UPPER NOZZLE		1				
C31	415964-9	JOINT HOLDER		1				
C36	743328-0	BRUSH		1				

Model No. VC3211M VACUUM CLEANER

Item	Parts No.	Description	I/C	QTY	N/O	Opt. 1	Opt. 2	NOTE
C41	743327-2	WIPER		1				
A08D	122512-4	NOZZLE ASS'Y		1				
C01	151449-8	ROLLER 40 COMPLETE		2				
C06	415962-3	ROLLER 14		2				
C11	256241-8	PIN 3		2				
C16	265871-4	TAPPING SCREW BT 4X16		6		100		
C21	154427-7	ELBOW JOINT COMPLETE		1				
C26	415965-7	UPPER NOZZLE		1				
C31	415964-9	JOINT HOLDER		1				
C36	743328-0	BRUSH		1				
C41	743327-2	WIPER		1				
A09C	195434-1	HOSE COMPLETE 38-2.5 SET		1	*			
A09D	195434-1	HOSE COMPLETE 38-2.5 SET		1	*			
A09-1C	195434-1	HOSE COMPLETE 38-2.5 SET	O	1				
C20	417191-4	CUFF LOCK		1				
C30	417306-3	SLEEVE		2				
C40	417307-1	FRONT CUFF		1				
C50	417586-1	STOPPER		2				
A09-1D	195434-1	HOSE COMPLETE 38-2.5 SET	O	1				
C20	417191-4	CUFF LOCK		1				
C30	417306-3	SLEEVE		2				
C40	417307-1	FRONT CUFF		1				
C50	417586-1	STOPPER		2				
A10C	192563-1	STRAIGHT PIPE		1				
A10D	192563-1	STRAIGHT PIPE		1				
A11C	192562-3	BENDING PIPE		1				
A11D	192562-3	BENDING PIPE		1				
A12C	410306-2	CORNER NOZZLE		1				
A12D	410306-2	CORNER NOZZLE		1				
A13C	451350-0	STOPPER		1				
A13D	451350-0	STOPPER		1				
A14C	911133-5	PAN HEAD SCREW M4X18		1	*	100		
A14D	911133-5	PAN HEAD SCREW M4X18		1	*	100		
A14-1C	911138-5	PAN HEAD SCREW M4X20	O	1		100		
A14-1D	911138-5	PAN HEAD SCREW M4X20	O	1		100		
E01A	655030-2	PLUG UK TYPE 16A-4H/110V		1				
E01C	655030-2	PLUG UK TYPE 16A-4H/110V		1				
E02A	654091-9	NON-INSULATED TERMINAL1.25-2AF		2		100		
E02C	654091-9	NON-INSULATED TERMINAL1.25-2AF		2		100		